

*Available with
exclusive Ink Monitor*

VANDERCOOK

SP15 REPRO PRESS

A low priced repro press with...

Big press versatility

- ... ideal for reproduction proofs
- reader proofs of type on galleys ■ short run printing, such as posters and menus
- proofing on acetate ■ laboratory testing of papers and inks ■ other proofing needs

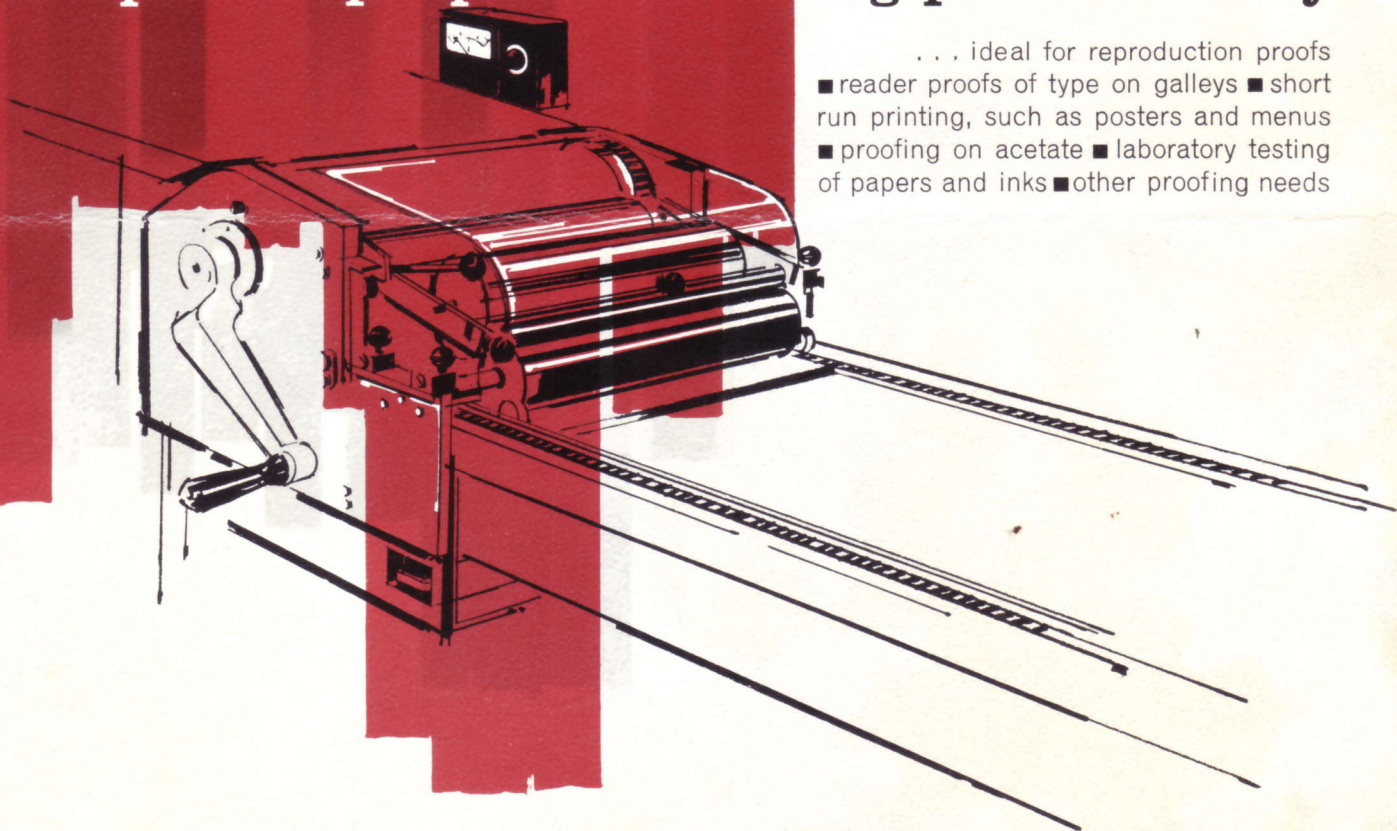

VANDERCOOK SP15

NOW WITH MORE STANDARD FEATURES
... AND ADDED OPTIONAL EQUIPMENT
INCLUDING THE EXCLUSIVE INK MONITOR

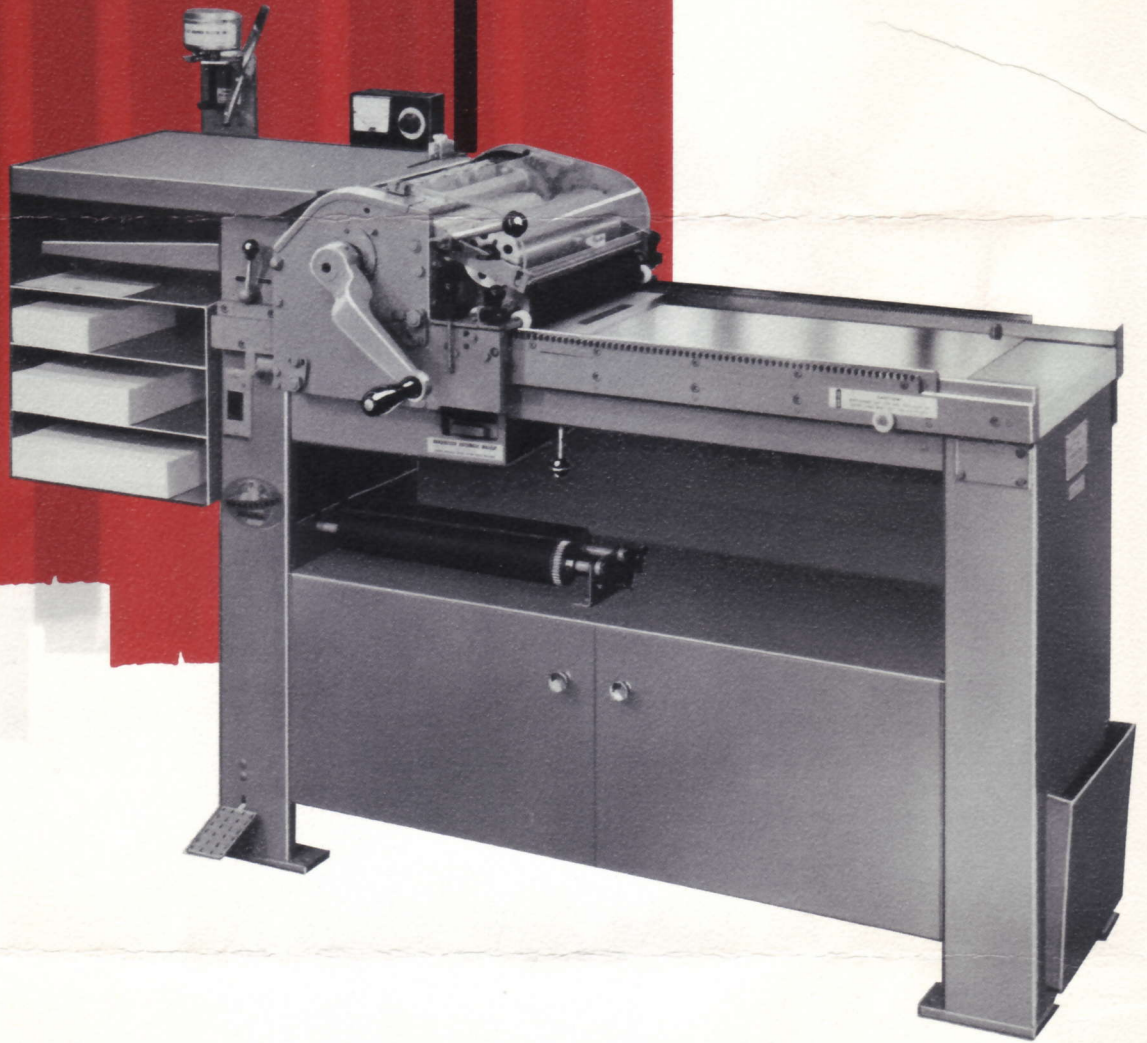

- The Vandercook SP15 is an extremely versatile repro press because of its many standard features and additional optional equipment that make it ideal for many proofing and printing needs.
- The SP15 is a compact machine taking up only 5'9" x 2'8" over-all floor space, but can handle sheets up to 14¾ x 20".
- This economical press with its flexibility for a wide variety of operations makes it the best test press value on the market.
- The SP15 is engineered to the same rigid standards as all equipment bearing the Vandercook name.

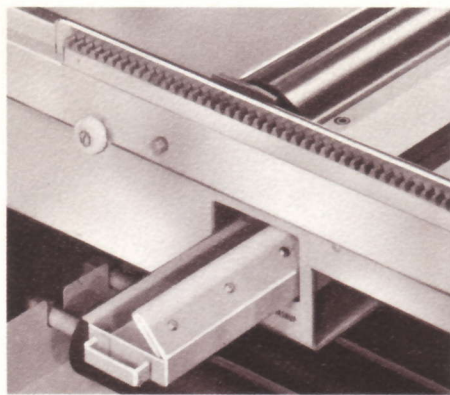

Power Ink Distribution and Automatic Washup . . .

Combination power inking and automatic washup saves time and rollers.

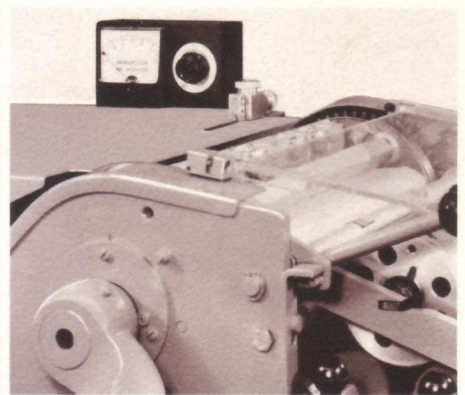

Ink Monitor . . . (optional equipment)

Accurately and continuously measures amount of ink in inking system. Enables operator to maintain color uniformity.

**THE VANDERCOOK SP15
INCLUDES THESE
SPECIAL FEATURES**

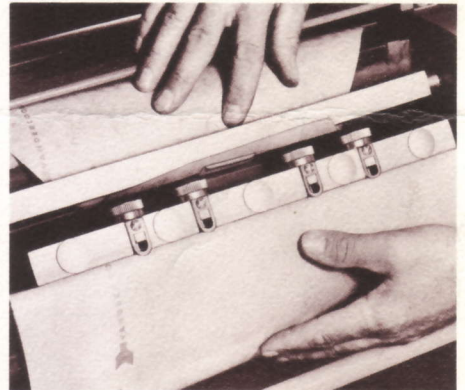

Tympan Guide . . .

The tympan guide provides for fast and easy packing changes.

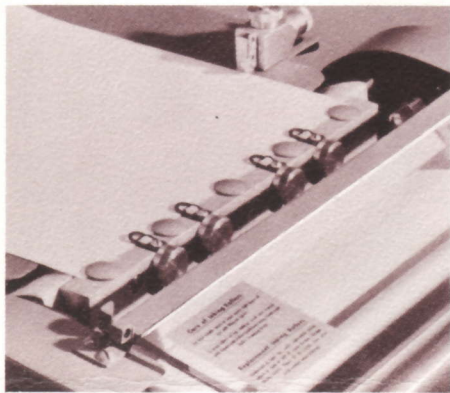

Foot Operated Gripper Bar . . .

Provides positive gripping for wide range of sheet sizes.

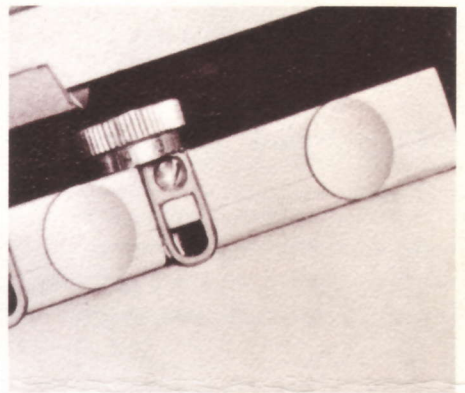

Sheet Guide Adjustment Knobs . .

Micrometer-type, wider knobs for easier turning, more accurate operation.

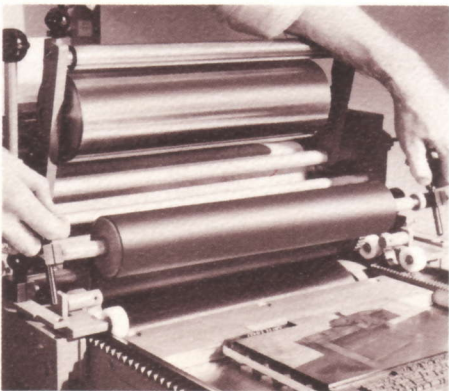

Quick Change Form Rollers . . .

Integrated construction of nylon bearings and height adjustment permits rollers to be changed in seconds.

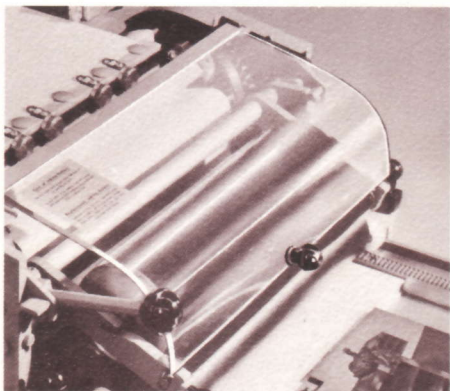

Curved Plastic Cover . . .

For protection against inking system contamination.

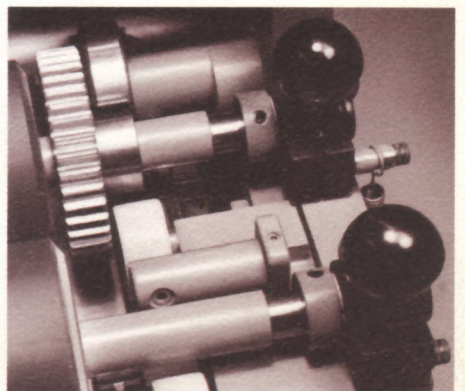

Form Roller Support System . . .

Form roller contact is controlled by the press bed bearers for the most exacting requirements.

ECONOMICAL USE OF FLOOR SPACE

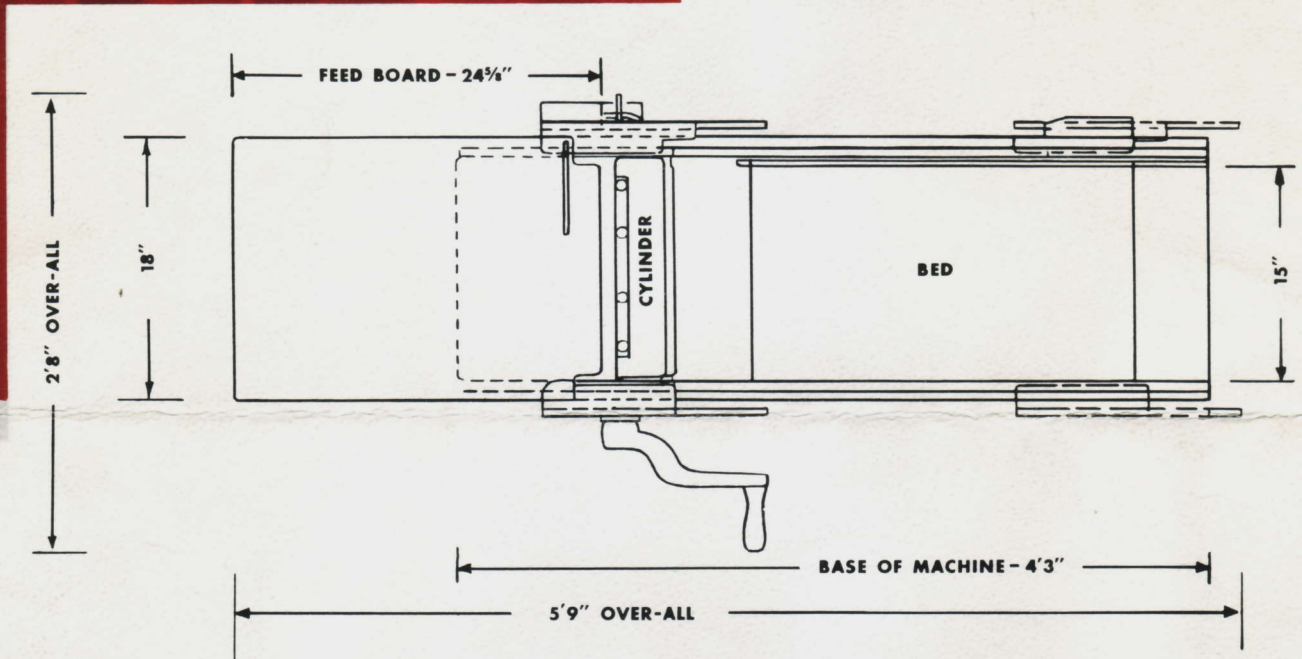

SPECIFICATIONS

Bed size 15" x 31 1/2" . . . Maximum Sheet 14 3/4" x 20" . . . Maximum form 14" x 18" . . . Height of Feed Board 41" . . . Floor Space, including all overhanging parts, 2'8" x 5'9" . . . Net Weight 705 Lbs. . . Crated Weight 855 Lbs. . . Packed for Export 1040 Lbs., 47 cu. ft. . . Machine Tool Gray Finish.

STANDARD EQUIPMENT

Power Ink Distribution and Automatic Wash-up, furnished with 1/12 h.p. 115 volts, 60 cycles, single phase A.C. motor . . . Bearer Controlled Form Roller Support System (pat-

ent pending) . . . Two 2 1/2" Vandercook Form Rollers . . . Steel Vibrator and Steel Rider Roller which automatically separate from form rollers when inking system is tripped (patented) . . . Curved Plastic Cover for inking system . . . Foot Operated Gripper Bar, with five grippers and four micrometer end sheet guides . . . Side Guide . . . Tympan Guide (patent pending) . . . Steel Paper Cabinet with Four Shelves 14 1/2" x 18", mounted under feed board . . . Steel Cabinet under bed equipped with doors on lower shelves . . . Brackets for storing two form rollers on open shelf in cabinet . . . Vandercook Roller Setting Gauge040" Hard Cylinder Packing . . . 25 Die Cut Drawsheets . . . 25 Die Cut

Undersheets . . . Head Dead Line Bar . . . Foot Lockup Bar . . . Tools.

OPTIONAL EQUIPMENT

Mobile Utility Cabinet . . . Illuminated Magnifier . . . Pressure Ink Well, with one pound Vandercook ink . . . Positive Lockup Bar . . . *Special .968" Bed with Galley Thickness Bed Plate . . . *Special Cylinder, undercut to .070" . . . *Center Side Guide, not adjustable (for laboratory testing) . . . Ink Monitor . . . Extra Set Vandercook Form Rollers with nylon bearings, Adjusting Knobs and Driving Gear . . . Split Vibrator and Split Rider (for laboratory testing) . . . Counter . . . Dust cover. *Available only when ordered with press.

Vandercook offers special proofing supplies to obtain maximum quality on Vandercook equipment: Repro Papers, Repro Inks, Replacement Inking Rollers, Roller-Blanket Conditioner, Tympan Paper, Frisket Paper, and Blankets.



VANDERCOOK

DIVISION OF ILLINOIS TOOL WORKS INC.

Sales/Service

Chicago, Ill. 60645
3601 W. Touhy Ave.
312/761-2100

Fairfield, N.J. 07006
387 Passaic Ave.
201/226-7515

Los Angeles, Calif. 90057
2411 W. 8th Ave.
213/388-9931